

Residential Ramps

REFERENCE:

ROBINS CODE OF ORDINANCE, ADOPTED INTERNATIONAL RESIDENTIAL CODE

Ramp: A walking surface that has a running slope steeper than 1 unit vertical in 20 units horizontal (5% slope).

1. **Ramps serving the required egress door** required by Section R311.2 shall have a slope not greater than 1:12 ratio. Other ramps shall have a maximum slope of 1:8.
2. **Ramps serving the required egress door** shall be protected from frost.
3. **Cross slope** of ramp runs shall not exceed 1:48.
4. **Ramp surfaces** shall be stable, firm and slip resistant.
5. **Clear width** the minimum, inside clear width of the opening between the opposing handrails must be at least 36 inches to accommodate a wheelchair. This means the ramp must be built at least 42 inches wide to allow for the one-inch spacing between the handrail and any surface, and the actual 1-1/2 inch handrail.
6. **Landings** shall be at the top and the bottom of each ramp run.
 - **Width.** A flat landing must be at the top and bottom of all ramps. Landings shall be at least as wide as the ramp itself and a minimum of 60" in length. IRC 311.8.2 requires a 3' minimum landing. A landing of the minimum size may not allow a person using a mobility device needs at least 60" to turn and adjust for the next ramp run, to move through a doorway at the top of a landing or change direction at the bottom or to enter and leave the ramp. Ramps that have a direction change shall be a minimum of 60" x 60".
 - **Doorways.** There shall be a floor or landing at top and bottom of each ramp, where doors open onto ramps, and where ramps change directions.

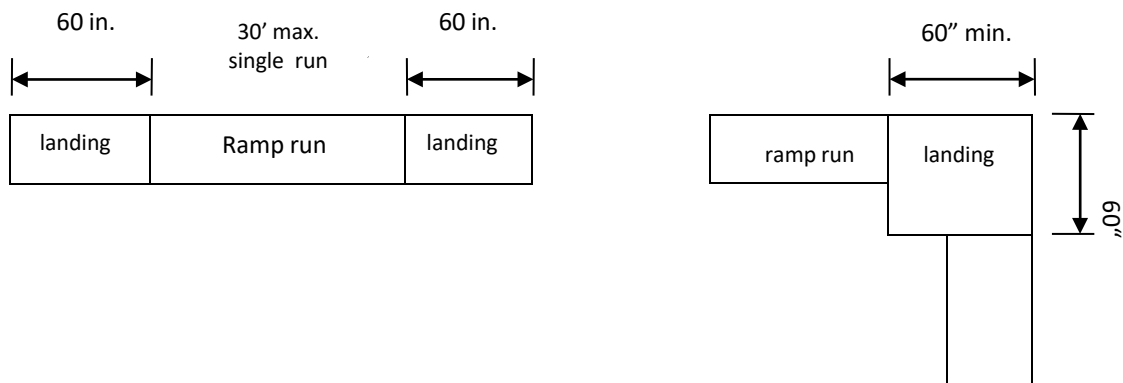

7. **Handrails required.** Handrails shall be provided on not less than one side of ramps exceeding a slope of 1:12.

- **Continuity.** Handrails where required on ramps shall be continuous within the full length of the ramp run. Handrail ends shall be returned or shall terminate in newel posts or safety terminal. Handrails adjacent to a wall shall have a space of not less than 1-1/2 inches between the wall and handrails.
- **Height.** The top of the gripping surface shall be 34 inches minimum and 38 inches maximum above finished surface of the ramp slope.

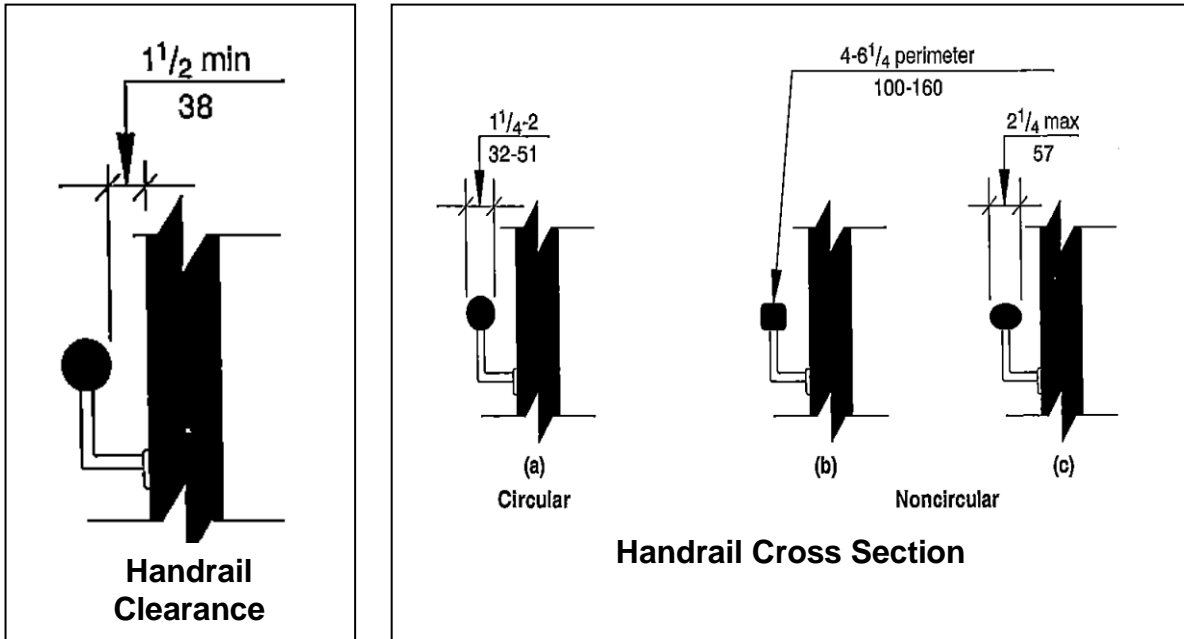

8. **Edge protection.** Edge protection shall comply with either (a) or (b) as shown below.

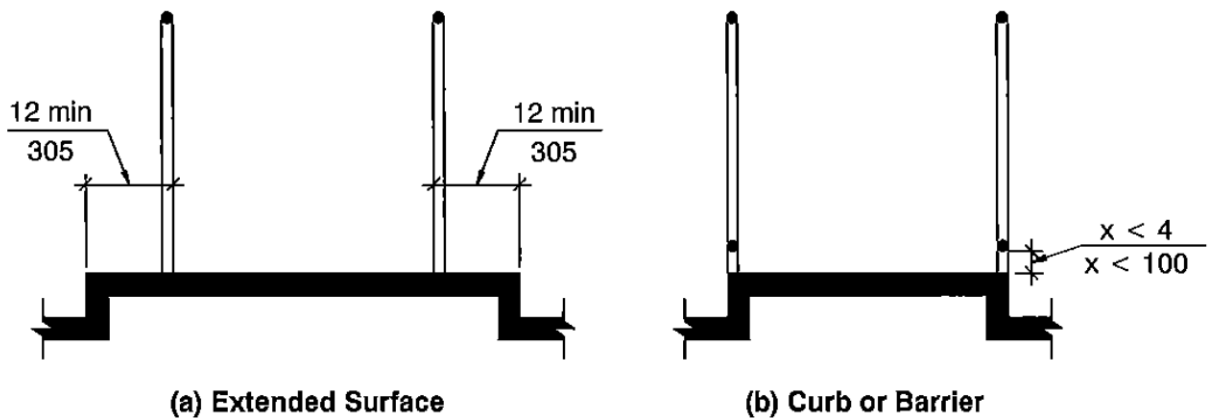

9. **Guards.** Ramps that are over 30 inches from grade shall also have guards installed.

- **Height.** The guard height shall not be less than 36 inches in height above the finished surface of ramp slope.
- **Openings.** Required guards shall not have openings from the walking surface to the required guard height that allow passage of a 4" diameter sphere.

10. **Indicate in the check box which details on the following pages will be used.**

Ramp configuration – check one:



Straight Ramp / Platform

U - Shape Ramp and Platforms

L- Shape Ramp and Platforms

11. **Indicate which door ramp will serve. If serving the required egress door frost protected footings are required.**

Required egress door.

Other than required egress door.

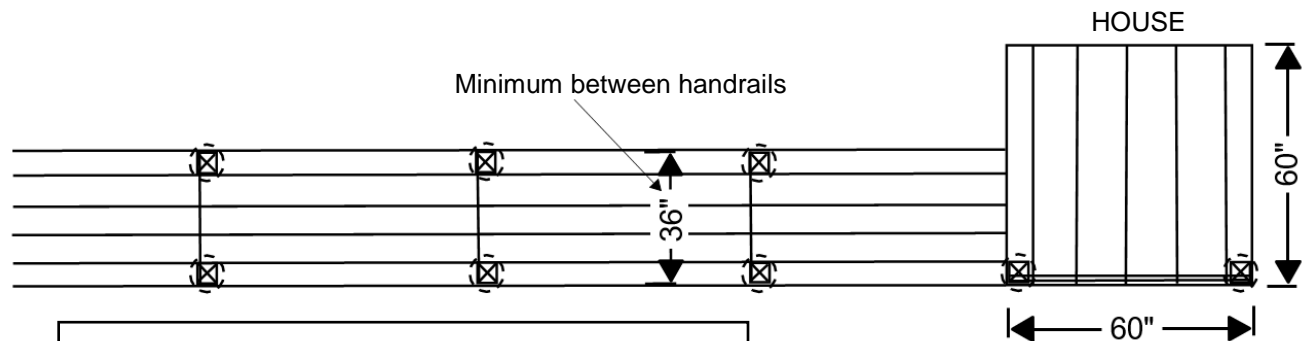

Footing size: _____

Joist size: _____

Beam size: ___ ply ___ x ___

Distance between supports (posts): show on drawing

