

**SIDEWALKS, SHARED USE PATHS, AND DRIVEWAYS****PART 1 - GENERAL****1.01 SECTION INCLUDES**

- A. Removal of Sidewalks, Shared Use Paths, and Driveways
- B. Installation of Sidewalks, Shared Use Paths, and Driveways

**1.02 DESCRIPTION OF WORK**

- A. Remove existing sidewalks, shared use paths, and driveways.
- B. Install shared use paths.
- C. Install sidewalk.
- D. Install driveway.

**1.03 SUBMITTALS**

Comply with Division 1 - General Provisions and Covenants, as well as the following:

- A. PCC mix design.
- B. Asphalt mix design.
- C. Brick source, absorption, compressive strength; samples of brick showing texture and color.
- D. Submit type and color of detectable warnings.
- E. Results of required testing.

**1.04 SUBSTITUTIONS**

Comply with Division 1 - General Provisions and Covenants.

**1.05 DELIVERY, STORAGE, AND HANDLING**

Comply with Division 1 - General Provisions and Covenants, as well as the following:

- A. Portland Cement Concrete:** See [Section 7010](#).
- B. Asphalt:** See [Section 7020](#).

**1.06 SCHEDULING AND CONFLICTS**

Comply with Division 1 - General Provisions and Covenants.

**1.07 SPECIAL REQUIREMENTS**

None.

**1.08 MEASUREMENT AND PAYMENT****A. Removal of Sidewalk, Shared Use Path, or Driveway:****1. Removal of Sidewalk:**

- a. **Measurement:** Measurement will be in square yards for the area of sidewalk removed.
- b. **Payment:** Payment will be at the unit price per square yard for the area of sidewalk removal.
- c. **Includes:** Unit price includes, but is not limited to, sawing, hauling, and disposal of materials removed.

**2. Removal of Shared Use Path:**

- a. **Measurement:** Measurement will be in square yards for the area of shared use path removed.
- b. **Payment:** Payment will be at the unit price per square yard for the area of shared use path removal.
- c. **Includes:** Unit price includes, but is not limited to, sawing, hauling, and disposal of materials removed.

**3. Removal of Driveway:**

- a. **Measurement:** Measurement will be in square yards for the area of driveway removed.
- b. **Payment:** Payment will be at the unit price per square yard for the area of driveway removal.
- c. **Includes:** Unit price includes, but is not limited to, sawing, hauling, and disposal of materials removed.

**B. Removal of Curb:**

1. **Measurement:** Measurement will be in linear feet for removal of curb by grinding or sawing, measured along the back of curb.
2. **Payment:** Payment will be at the unit price per linear foot for the removal of curb.
3. **Includes:** Unit price includes, but is not limited to, hauling and disposal of materials removed.

**C. Shared Use Paths:**

1. **Measurement:** Each type and thickness of shared use paths will be measured in square yards. The area of manholes, intakes, or other fixtures in the pavement will not be deducted from the measured pavement area.
2. **Payment:** Payment will be at the unit price per square yard for each type and thickness of shared use path.
3. **Includes:** Unit price includes, but is not limited to, subgrade preparation, jointing, sampling, slope and smoothness testing and correction, and testing.

**D. Special Subgrade Preparation for Shared Use Paths:**

1. **Measurement:** Measurement will be in square yards for special subgrade preparation. Measured area will include 2 feet outside of the pavement on either side of the path.
2. **Payment:** Payment will be at the unit price per square yard for the area of special subgrade preparation.
3. **Includes:** Unit price includes, but is not limited to, water required to bring subgrade moisture content to within the required limits.

**1.08 MEASUREMENT AND PAYMENT (Continued)****E. PCC Sidewalk:**

1. **Measurement:** Each thickness of PCC sidewalk will be measured in square yards. The area of manholes, intakes, or other fixtures in the pavement will not be deducted from the measured pavement area.
2. **Payment:** Payment will be at the unit price per square yard for each thickness of PCC sidewalk.
3. **Includes:** Unit price includes, but is not limited to, minor grade adjustments at driveways and other intersections, subgrade preparation, formwork, additional thickness at thickened edges, jointing, sampling, slope and smoothness testing and correction, and testing.

**F. Brick/Paver Sidewalk with Pavement Base:**

1. **Measurement:** Measurement will be in square yards for the area of brick/paver sidewalk placed on a pavement base. The area of pavement base will not be measured separately.
2. **Payment:** Payment will be at the unit price per square yard for the area of brick/paver sidewalk.
3. **Includes:** Unit price includes, but is not limited to, subgrade preparation, pavement base, setting bed, neoprene asphalt adhesive for asphalt setting bed, setting the bricks/pavers, installing weep holes and associated materials, and sand/cement joint filler.

**G. Detectable Warnings:**

1. **Measurement:** Measurement will be in square feet for the area of detectable warnings installed. Paved area beneath detectable warnings will be measured with sidewalk or shared use path item.
2. **Payment:** Payment will be at the unit price per square foot for the area of detectable warnings installed.
3. **Includes:** Unit price includes, but is not limited to, steel bar supports and manufactured detectable warning panels.

**H. Driveways:****1. Paved Driveways:**

- a. **Measurement:** Each type and thickness will be measured in square yards. The area of manholes, intakes, or other fixtures in the pavement will not be deducted from the measured pavement area.
- b. **Payment:** Payment will be at the unit price for each type and thickness of driveway.
- c. **Includes:** Unit price includes, but is not limited to, excavation, subgrade preparation, jointing, sampling, and testing.

**2. Granular Surfacing for Driveways by Square Yards:**

- a. **Measurement:** Measurement will be in square yards for the thickness of granular surfacing placed.
- b. **Payment:** Payment will be at the unit price per square yard for each thickness of granular surfacing placed.
- c. **Includes:** Unit price includes, but is not limited to, excavation and preparation of subgrade.

**1.08 MEASUREMENT AND PAYMENT (Continued)****3. Granular Surfacing for Driveways by Tons:**

- a. **Measurement:** Measurement will be in tons for the thickness of granular surfacing placed.
- b. **Payment:** Payment will be at the unit price per ton for each thickness of granular surfacing placed.
- c. **Includes:** Unit price includes, but is not limited to, excavation and preparation of subgrade.

**I. Sidewalk, Shared Use Path, and Driveway Assurance Testing:****1. Sidewalk Assurance Testing:**

- a. The Contractor will not be responsible for concrete compression or asphalt density testing unless otherwise specified in the contract documents.
- b. If the contract documents specify that the Contractor is responsible for concrete compression and asphalt density testing, performed by an independent testing laboratory hired by the Contractor, measurement and payment will be as follows:
  - 1) Measurement: Lump sum item; no measurement will be made.
  - 2) Payment: Payment will be at the contract lump sum price.
- c. The Contractor will be responsible for payments associated with all retesting resulting from failure of initial tests.

**2. Shared Use Path Assurance Testing:**

- a. The Contractor will not be responsible for concrete compression or asphalt density testing unless otherwise specified in the contract documents.
- b. If the contract documents specify that the Contractor is responsible for concrete compression and asphalt density testing, performed by an independent testing laboratory hired by the Contractor, measurement and payment will be as follows:
  - 1) Measurement: Lump sum item; no measurement will be made.
  - 2) Payment: Payment will be at the contract lump sum price.
- c. The Contractor will be responsible for payments associated with all retesting resulting from failure of initial tests.

**3. Driveway Assurance Testing:**

- a. The Contractor will not be responsible for concrete compression or asphalt density testing unless otherwise specified in the contract documents.
- b. If the contract documents specify that the Contractor is responsible for concrete compression and asphalt density testing, performed by an independent testing laboratory hired by the Contractor, measurement and payment will be as follows:
  - 1) Measurement: Lump sum item; no measurement will be made.
  - 2) Payment: Payment will be at the contract lump sum price.
- c. The Contractor will be responsible for payments associated with all retesting resulting from failure of initial tests.

**PART 2 - PRODUCTS****2.01 PORTLAND CEMENT CONCRETE**

- A. Use Class A or C concrete for sidewalks and driveways and Class C for shared use paths with materials complying with [Section 7010](#). Use coarse aggregate of Class 2 durability or better.
- B. Comply with the following for PCC mixes for sidewalks, shared use paths, and driveways unless otherwise approved by the Engineer.

**Table 7030.01: PCC Mixes**

	<b>Machine Finish</b>	<b>Hand Finish</b>
Type of Concrete	Class A or C	Class A or C
Slump Minimum	1/2 in.	1/2 in.
Slump Maximum	2 1/2 in.	4 in.
Percent Air Content		
• Target	7%	7%
• Minimum	6%	6%
• Maximum	8 1/2%	8 1/2%

**2.02 ASPHALT**

Comply with [Section 7020](#) for mix design.

- A. Use Low Traffic (LT), 1/2 inch or 3/8 inch mix.
- B. For shared use paths adjacent to pavement that also functions as the pavement shoulder, use Low Traffic (LT), 1/2 inch mix.
- C. Use asphalt binder complying with [Section 7020](#) with a performance grade of PG 58-28S or 58-34S.

**2.03 BRICKS/PAVERS**

- A. **Clay Bricks:** Use 8 inch by 4 inch by 2 1/4 inch thick clay paving bricks with straight edges or a maximum chamfer of 1/8 inch manufactured to comply with ASTM C 902, Class SX, Type I. Color selection and surface texture as approved by the Engineer.
- B. **Concrete Pavers:** Supply as specified in the contract documents. Use pavers with straight edges or a maximum chamfer of 1/8 inch.

**2.04 SETTING BED FOR BRICKS/PAVERS****A. Asphalt:**

- Mixture:** Proportion mix using 7% asphalt binder and 93% fine aggregate. Apportion each ton in the approximate ratio of 145 pounds asphalt binder to 1,855 pounds sand. Maintain mix temperature at approximately 250°F during placement.
- Asphalt Binder:** Use asphalt binder complying with [Section 7020](#) with a performance grade of PG 58-28 or 64-22.
- Fine Aggregate:** Use clean, hard sand with durable particles free from adherent coating, lumps of clay, alkali salts, and organic matter. Use sand that is uniformly graded from coarse to fine with all passing the No. 4 sieve and meeting AASHTO T 27.

**2.04 SETTING BED FOR BRICKS/PAVERS (CONTINUED)**

- B. Pre-mixed High Performance Cold Mix:** If allowed, substitute a pre-mixed high performance cold mix product for the asphalt setting bed generally meeting the asphalt mixture requirements noted above.
- C. Sand:** Use clean, hand sand free from deleterious materials. Use sand meeting ASTM C 33 that is uniformly graded with all passing the No. 4 sieve and 3% or less passing the No. 200 sieve.

**2.05 NEOPRENE MODIFIED ASPHALT ADHESIVE FOR BRICKS/PAVERS****A. Mastic (Asphalt Adhesive):**

<b>Solids (Base):</b>	74% to 76%
<b>Pounds per Gallon:</b>	8 to 8 1/2 pounds
<b>Solvent:</b>	Mineral spirits with a flash point above 100° F

**B. Base (2% Neoprene, 10% Asbestos-free Fiber, 88% Asphalt):**

<b>Melting Point:</b>	200° F minimum according to ASTM D 36
<b>Penetration:</b>	23 to 27 according to ASTM D 5
<b>Ductility:</b>	1250 mm minimum according to ASTM D 113 @ 25° C, and a rate of 50 mm/minute

**2.06 BRICK/PAVER JOINT FILLER**

Dry sand-cement mixture consisting of one part masonry cement complying with ASTM C 91 and three parts sand complying with ASTM C 144 and passing the No. 16 sieve. Provide colored cement as specified in the contract documents.

**2.07 DETECTABLE WARNINGS**

Use manufactured detectable warning panels with a non-slip surface and raised truncated domes. Comply with the Proposed Accessibility Guidelines for Pedestrian Facilities in the Public Right-of-Way (also known as PROWAG) for contrast and dimension requirements. Also comply with [Iowa DOT Materials I.M. 411](#).

**2.08 GRANULAR DRIVEWAY SURFACING**

Class A crushed stone or Class C gravel complying with [Iowa DOT Section 2315](#).

**2.09 ISOLATION AND EXPANSION JOINT SEALANT**

Use a polyurethane, self-leveling sealant complying with ASTM C 920. Application temperature range of 40 to 120°F. Minimum elongation 700%.

**PART 3 - EXECUTION****3.01 REMOVALS**

- A. Remove sidewalks, shared use paths, driveways, bricks, and curbs to the removal limits specified in the contract documents.
- B. Saw pavement full depth in straight lines to the specified removal limits.
- C. Remove to the specified removal limits without damage to adjacent property, trees, utilities, or pavement that are to remain in place.
- D. Salvage and stockpile all bricks removed.
- E. Grind or saw existing curbs at locations specified in the contract documents to install sidewalks, shared use paths, and driveways.
- F. Dispose of rubble and debris resulting from removal operations.

**3.02 SUBGRADE PREPARATION****A. Shared Use Paths:**

- 1. **Subgrade Preparation:** Comply with [Iowa DOT Section 2109](#).
- 2. **Special Subgrade Preparation:**
  - a. Construct subgrade to final elevation.
  - b. Scarify and mix the top 6 inches of subgrade material to a width equal to that of the proposed pavement, plus 2 feet on each side.
  - c. Compact loose subgrade material with Type A compaction complying with [Section 2010](#).
  - d. Proof roll compacted subgrade according to [Section 2010](#).

**B. Sidewalks and Driveways:**

- 1. Remove all vegetation and roots from ground surface.
- 2. Construct grade to final subgrade elevation.
  - a. Cut area: Remove all material that will be displaced by the sidewalk.
  - b. Fill area: Scarify the surface to be covered with embankment to a depth of at least 6 inches and compact. Construct embankment in lifts of 6 inches or less and compact each lift. Tamp surface with a mechanical tamper until firm and unyielding.
- 3. Remove all soft, spongy, or yielding spots and fill the void with suitable backfill material.

**3.03 ADJUSTMENT OF FIXTURES**

- A. Adjust fixtures to conform to the finished pavement surface. Cooperate and coordinate with the utility agency to ensure proper fixture adjustment.
- B. Comply with [Sections 5020](#), [6010](#), or [8010](#) as appropriate.

**3.04 PCC SIDEWALKS, SHARED USE PATHS, AND DRIVEWAYS**

Construct sidewalks and shared use paths to the line and running slope specified in the contract documents. Unless otherwise specified in the contract documents, the maximum cross slope is 2.0%, target cross slope is 1.5%, and minimum cross slope is 1.0%.

**A. Form Setting:** Comply with [Section 7010](#) with the following additional requirements and exceptions.

1. Slip form paving equipment may be allowed in lieu of setting forms, if approved by the Engineer.
2. Wood forms are allowed.
3. Use of an automated subgrade trimmer is not required.
4. Set forms true to line and grade and hold them rigidly in place by stakes placed outside the forms and flush with or below the top edge of the forms.
5. Measure or stake as required to construct project elements. If either of the following is met and construction survey is not a bid item, the Contracting Authority will verify that form work complies with the design requirements:
  - a. The tolerance between the design running slope and the maximum allowable running slope is less than 1.0%.
  - b. The tolerance between the design cross slope of the sidewalk, turning space, or shared use path and the maximum allowable cross slope is less than 0.5%.

If adequate tolerances are contained in the design, the Contracting Authority will not verify the form work for the construction of sidewalks or shared use paths. If field adjustments cause changes that will bring the facility into the range of tolerances shown above, notify the Engineer prior to construction.

**B. Concrete Pavement Placement:**

1. **Shared Use Paths:** Comply with [Section 7010](#).
2. **Sidewalk:**
  - a. Maintain moist subgrade in front of paving operation
  - b. Deposit concrete on the subgrade as required to minimize rehandling to prevent segregation.
  - c. Hand spread with shovels, not rakes.
  - d. Place concrete as required to slightly overfill the space between the forms.
  - e. For thicknesses less than 5 inches, consolidate by knifing with hand tools. When thickness is 5 inches or greater, consolidate with hand or mechanical vibrators meeting [Section 7010, 3.01, C, 3](#). Smooth by use of a straightedge.
  - f. Do not contaminate freshly mixed concrete with earth or other foreign materials.
3. **Driveways:** Comply with [Figures 7030.101](#) and [7030.102](#) and [Section 7010](#). The use of a paving machine is not required.

**C. Finishing:**

1. **Shared Use Paths and Driveways:**
  - a. Comply with [Section 7010](#).
  - b. Provide a burlap drag or broom finish.



**3.04 PCC SIDEWALKS, SHARED USE PATHS, AND DRIVEWAYS (Continued)****2. Sidewalks:**

- a. Use a wood float to depress the large aggregate and create a dense surface.
- b. Allow concrete to set until all shine has disappeared from the surface.
- c. Smooth with a metal trowel until surface is free from defects and blemishes.
- d. Construct joints by sawing or by using a jointer or groover tool.
- e. Finish edges of sidewalk or driveway with an edging tool having a radius of approximately 1/2 inch. Ensure tool marks do not appear on the finished surface.
- f. Brush with a soft broom at right angles to the side forms to provide a non-skid surface.

**D. Curing:** Cure according to [Section 7010](#).

**E. Form Removal:** Comply with [Section 7010](#).

**F. Jointing:****1. Construction Joints:**

- a. Locate construction joints to provide uniform joint spacing.
- b. Place a construction joint at the close of each day's work or when depositing of concrete is stopped for 45 minutes or more.
- c. Form construction joint by using a header board. Set perpendicular to the surface and at right angles to the centerline.

**2. Transverse Contraction Joints:****a. Shared Use Paths:**

- 1) Space transverse joints equal to the width of the shared use path, or as specified in the contract documents.
- 2) Saw contraction joints according to [Section 7010](#).

**b. Sidewalks and Driveways:**

- 1) Space sidewalk contraction joints equal to the width of the sidewalk.
- 2) Space driveway contraction joints so panel length does not exceed 12 feet.
- 3) Form transverse contraction joints to a depth of 1 1/4 inches with a pointed trowel or jointing tool. In lieu of forming, joints may be sawed within 12 hours of placement with a 1/8 inch blade saw to a depth of 1/3 the pavement thickness. Use a straightedge if joints are sawed with a hand-held saw.

**3. Longitudinal Contraction Joints:**

**a. Shared Use Paths and Sidewalks:** Saw joint to 1/8 inch wide and to a depth of 1/3 the pavement thickness.

**b. Driveways:**

- 1) Space longitudinal contraction joints so panel width does not exceed 12 feet.
- 2) Form longitudinal contraction joints to a depth of 1 1/4 inches with a pointed trowel or jointing tool. In lieu of forming, joints may be sawed with a 1/8 inch blade saw to a depth of 1/3 the pavement thickness. Use a straightedge if joints are sawed with a hand-held saw.

**4. Isolation Joints:**

- a. Install isolation joints where sidewalks, shared use paths, or driveways abut roadway pavement, parking lots, buildings, and structures.
- b. For a sidewalk constructed with a driveway, install an isolation joint on the property side of the sidewalk and a 'C' or 'E' joint on the street side of the sidewalk.
- c. Install a 1/2 inch or 3/4 inch thick strip of preformed resilient joint material, according to [Section 7010](#), to the full depth of concrete. Trim any isolation joint material protruding above the finished work to the level of the abutting concrete.
- d. If the isolation joint is to be sealed, place the preformed material 1/2 inch below the level of the abutting concrete.

**3.04 PCC SIDEWALKS, SHARED USE PATHS, AND DRIVEWAYS (Continued)****5. Joint Sealing:**

- a. Do not seal construction or contraction joints in sidewalks, shared use paths, or driveways.
- b. If sealing of expansion or isolation joints is specified in the contract documents, trim preformed joint material to a depth of 1/2 inch below the concrete surface. Ensure the joint is clean and dry. Install joint sealant per manufacturer's recommendations.

**3.05 ASPHALT SHARED USE PATHS AND DRIVEWAYS**

Construct sidewalks and shared use paths to the line and running slope specified in the contract documents. Unless otherwise specified in the contract documents, the maximum cross slope is 2.0%, target cross slope is 1.5%, and minimum cross slope is 1.0%. Comply with [Section 7020](#).

**3.06 BRICK/PAVER SIDEWALKS WITH A PAVEMENT BASE****A. General:**

1. Comply with [Figure 7030.203](#).
2. Use a cross-section and patterns as specified in the contract documents or approved by the Engineer.
3. Do not use broken bricks or materials with stained faces in the paving areas.
4. Construct the concrete base to comply with PCC sidewalk construction specifications.

**B. Setting Bed:**

1. Place 3/4 inch depth control bars on the base to serve as guides for the striking board. Shim depth control bars as necessary to adjust bedding thickness and to ensure the top surface of pavers will be at the required finished grade.
2. Place bedding material between the parallel depth control bars. Pull striking board over bars several times. After each pass, spread fresh bedding material over low or porous spots to produce a smooth and even setting bed. After placing and smoothing each section, advance depth control bars to next section. After removal of depth control bars and shims, carefully fill any depressions that remain.
3. While still hot, roll the asphalt setting bed with a power roller to a nominal depth of 3/4 inch.
4. Ensure the joints in the concrete base do not project through the asphalt setting bed.
5. Apply neoprene modified asphalt adhesive over the top surface of the cooled asphalt setting bed with notched trowel with serration not exceeding 1/16 inch. Allow adhesive to dry to the touch before placing pavers.

**C. Weep Holes:**

1. Install 2 inch diameter, 12 inch long, PVC pipe even with the top of the asphalt setting bed at the locations identified on the plans.
2. Fill pipe with 3/4 inch clean rock and cover weep hole with engineering fabric.
3. Install minimum of 12 inch deep and 12 inch wide reservoir of clean 3/4 inch rock around the pipe below the PCC sidewalk base or extend the rock reservoir to the pavement subdrain.

**3.06 BRICK/PAVER SIDEWALKS WITH A PAVEMENT BASE (Continued)****D. Bricks/Pavers:**

1. Place the bricks/pavers by hand in straight courses with hand tight joints and uniform top surface.
2. Sweep dry joint filler into joints until the joints are completely filled.
3. Fog surface lightly with water to cure cement.
4. Clean any cement stains from bricks/pavers surface. Remove stains from other concrete surfaces.

**E. Protection:** Protect newly laid bricks/pavers at all times using panels of plywood. Panels can be advanced as work progresses; however, keep the plywood protection in areas that will be subjected to movement of materials, workers, and equipment. Take precautions in order to avoid depressions and protect brick/paver alignment until cured and ready for pedestrian or vehicle traffic.

**3.07 DETECTABLE WARNING INSTALLATION**

Set detectable warning panels in fresh concrete according to the manufacturer's recommendations and [Figure 7030.210](#).

**3.08 SLOPE AND SMOOTHNESS TESTING****A. Slope for Sidewalks, Curb Ramps, Turning Spaces, and Shared Use Paths:**

1. Complete slope measurements and documentation according to [Iowa DOT Materials I.M. 363](#).
2. At no additional cost to the Contracting Authority, remove and replace all sections not meeting PROWAG requirements as detailed in [SUDAS Design Manual Section 12A-2](#).

**B. Smoothness for Shared Use Paths and Driveways:**

1. Check finished surface with a 10 foot straightedge placed parallel to the centerline. Mark areas showing high spots of more than 1/4 of an inch in 10 feet.
2. If directed by the Engineer, correct marked areas by grinding down with an approved grinding tool to an elevation where the area will not show deviations in excess of 1/8 inch.

**3.09 GRANULAR DRIVEWAY SURFACING**

Comply with [Iowa DOT Section 2315](#).

**3.10 CLEANING**

- A. Remove all litter and construction materials or tools immediately after the end of the curing period.
- B. Remove excess dirt from the site.
- C. Broom clean completed sidewalks, shared use paths, and driveways.

**3.11 MATERIAL TESTING**

- A. General:** When testing is specified in the contract documents as the Contractor's responsibility, provide testing using the services of an independent testing laboratory approved by the Engineer.
- B. Concrete Compression Tests:** When the concrete volume placed on a single day exceeds 20 cubic yards, comply with the following test requirements. When deficiencies are encountered, comply with [Section 7010, 3.07, E](#).
1. Prepare at least two test cylinders per day.
  2. If the concrete volume placed on a single day exceeds 200 cubic yards, prepare two test cylinders for each 200 cubic yards placed.
  3. Provide 7 and 28 calendar day tests according to ASTM C 39. Minimum compressive strength is 2,000 psi at 7 days and 4,000 psi at 28 days.
- C. Asphalt Density and Thickness Tests:** When the area of asphalt placed on a single day exceeds 100 square yards, comply with the following test requirement. When deficiencies are encountered, comply with [Section 7020, 3.04, A](#).
1. Prepare at least two cores per day.
  2. If the area of asphalt placed on a single day exceeds 2,000 square yards, prepare two cores for each 2,000 square yards placed.

**3.12 SIDEWALK AND CURB RAMP COMPLIANCE**

Compliance with cross slopes and grades, as well as all other elements, for sidewalks and curb ramps is crucial. If the construction cannot be completed as specified in the contract documents, it may be necessary to adjust slopes within the accepted legal limitations. Contact the Engineer prior to placement of the concrete if changes from the values specified in the contract documents are being made.

END OF SECTION

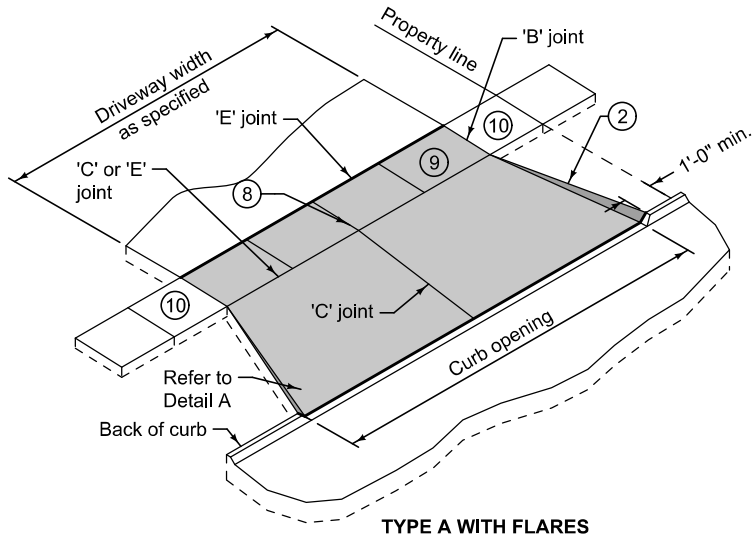

**TYPE A WITH FLARES**

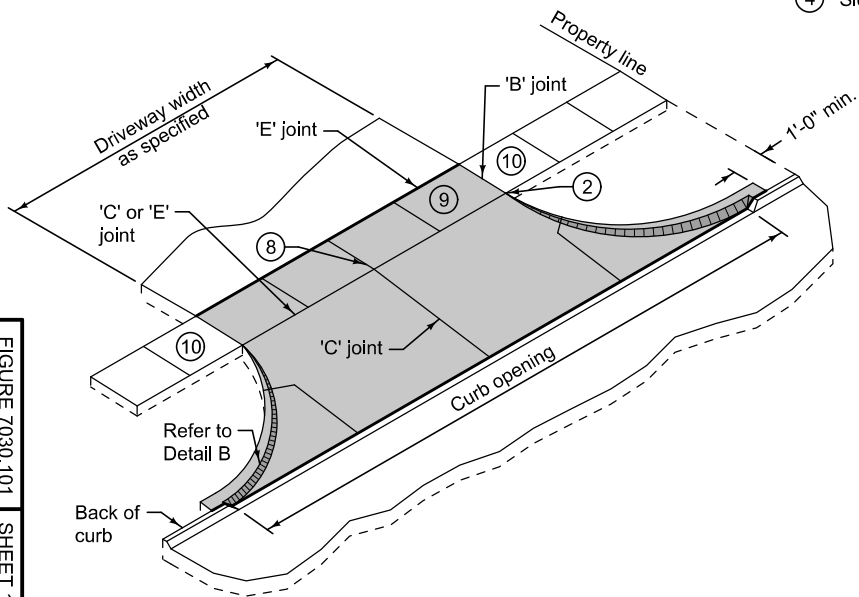

**TYPE A WITH RADII**

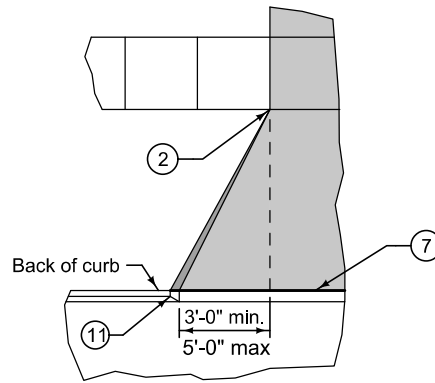

**DETAIL A**  
(Residential/Agricultural Only)

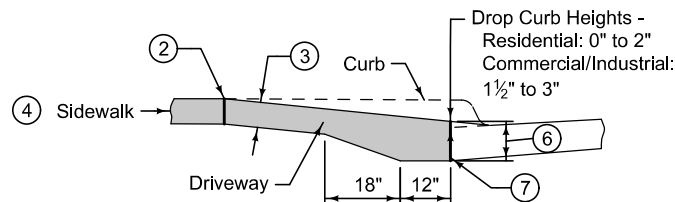

**TYPICAL SECTION**

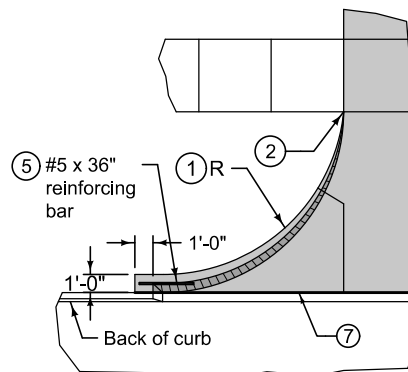

**DETAIL B**

- ① Driveway radius (R).  
Residential: 10 foot minimum, 15 foot maximum.  
Commercial and industrial: As specified in the contract documents.
- ② Transition the curb height to 0 inches at end of taper/radius or at the front edge of sidewalk. Do not extend raised curb across sidewalk.
- ③ Pavement thickness.  
Residential: 6 inches minimum.  
Commercial and industrial: 7 inches minimum.
- ④ Sidewalk thickness through driveway to match thickness of driveway.
- ⑤ Center reinforcing bar vertically in the pavement.
- ⑥ Match thickness of adjacent roadway, 8 inches minimum.
- ⑦ Provide 'E' joint at back of curb unless 'B' joint is specified.
- ⑧ For alleys, invert the pavement crown 2% toward center of alley.
- ⑨ Target cross slope of 1.5% with a maximum cross slope of 2.0%. If specified in the contract documents, construct the sidewalk through the driveway 5 feet wide to serve as a passing space.
- ⑩ If cross slope of adjacent sidewalk panel exceeds 2.0%, remove and replace to transition from existing sidewalk to sidewalk through driveway. If elevation change requires a curb ramp, comply with Figure 7030.205; verify need for detectable warning panel with Engineer.
- ⑪ Transition street curb at minimum 1:1 slope to meet driveway curb.

	<b>SUDAS</b>	<small>REVISION</small> 4   2022 Edition
	<b>7030.101</b>	<small>SHEET 1 of 1</small>
<b>SUDAS Standard Specifications</b>		
<b>CONCRETE DRIVEWAY, TYPE A</b>		

## Cutting out curb & street prohibited in Robins

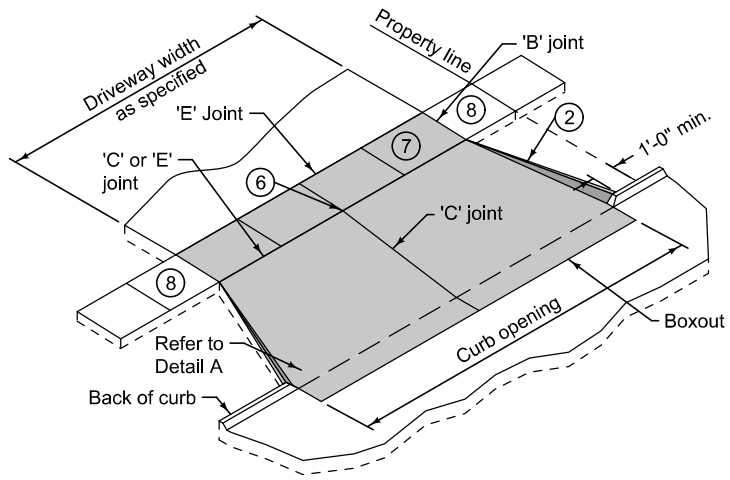

**TYPE B WITH FLARES**

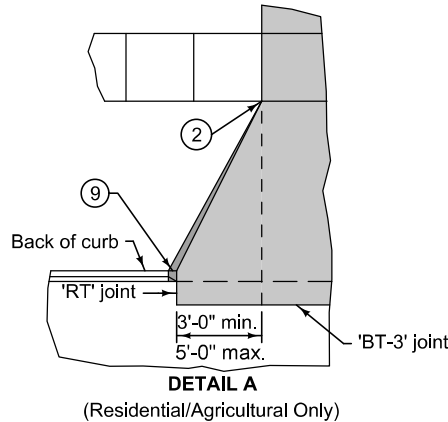

**DETAIL A**

(Residential/Agricultural Only)

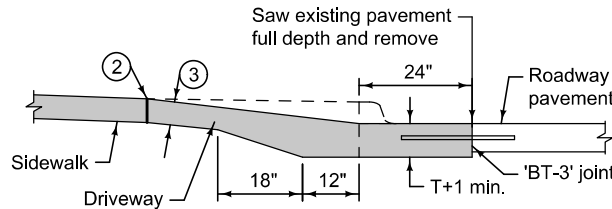

**SECTION A-A**

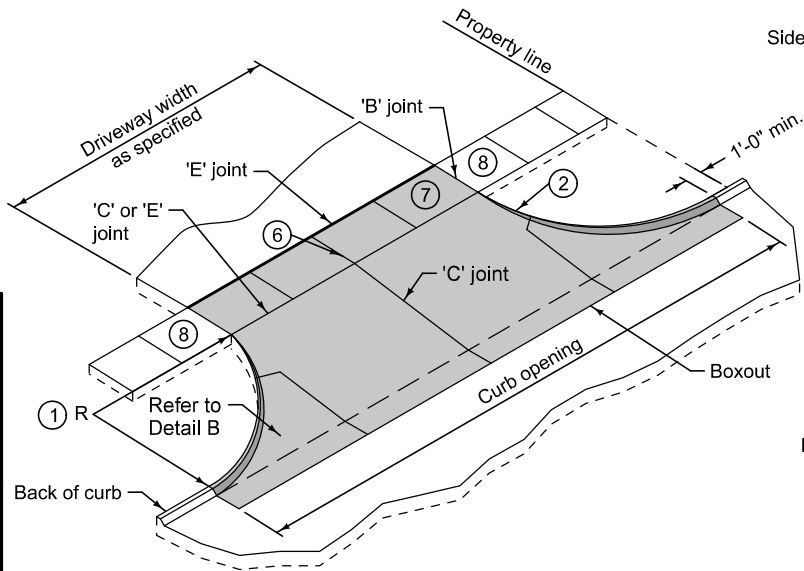

**TYPE B WITH RADII**

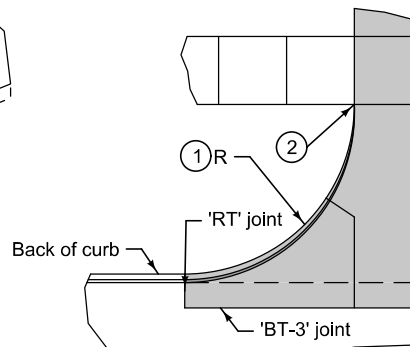

**DETAIL B**

- ① Driveway radius (R).  
Residential: 10 foot minimum, 15 foot maximum.  
Commercial and industrial: As specified in the contract documents.
- ② Transition the curb height to 0 inches at end of taper/radius or at the front edge of sidewalk. Do not extend raised curb cross sidewalk.
- ③ Pavement thickness.  
Residential: 6 inches minimum.  
Commercial and industrial: 7 inches minimum.
- ④ Sidewalk thickness through driveway to match thickness of driveway.
- ⑤ If longitudinal joint is located 48 inches or less from the back of curb, extend boxout to joint line. Full depth saw cut is still required.
- ⑥ For alleys, invert the pavement crown 2% toward the center of the alley.
- ⑦ Target cross slope of 1.5% with a maximum cross slope of 2.0%. If specified in the contract documents, construct the sidewalk through the driveway 5 feet wide to serve as a passing space.
- ⑧ If cross slope of adjacent sidewalk panel exceeds 2.0%, remove and replace to transition from existing sidewalk to sidewalk through driveway. If the elevation change requires a curb ramp, comply with Figure 7030.205; verify need for detectable warning panel with Engineer.
- ⑨ Transition street curb at minimum 1:1 slope to meet driveway curb.

	REVISION 5   2023 Edition
	7030.102
SHEET 1 of 1	
<b>SUDAS Standard Specifications</b>	
<b>CONCRETE DRIVEWAY, TYPE B</b>	

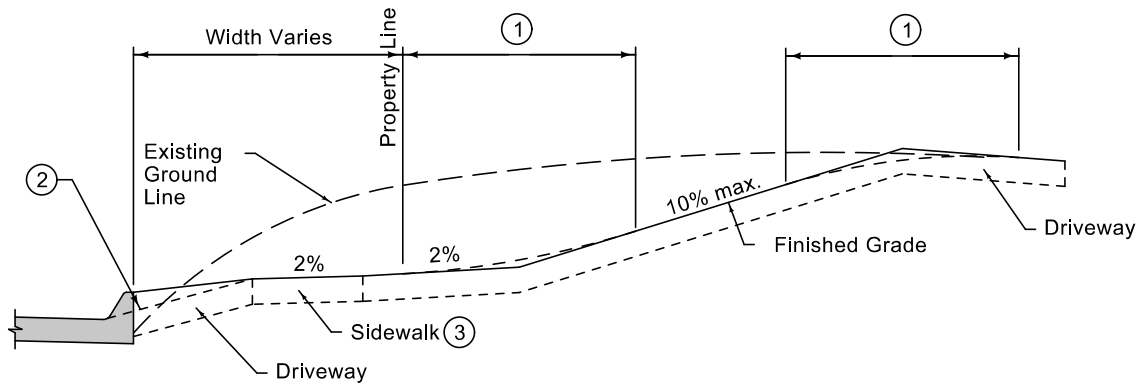

TYPICAL CUT SECTION

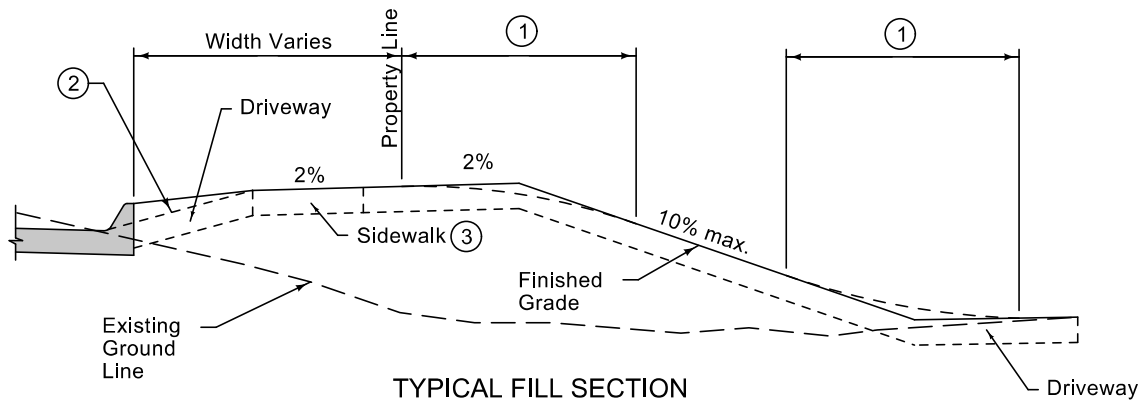

TYPICAL FILL SECTION

- ① 10 foot vertical curve required for 5% or greater change in grade.
- ② Slope varies. See contract documents.
- ③ Target cross slope of 1.5% with a maximum cross slope of 2.0%.

	REVISION 2   10-20-15
	<b>SUDAS</b> <b>7030.103</b>
	SHEET 1 of 1
SUDAS Standard Specifications	
DRIVEWAY GRADING	

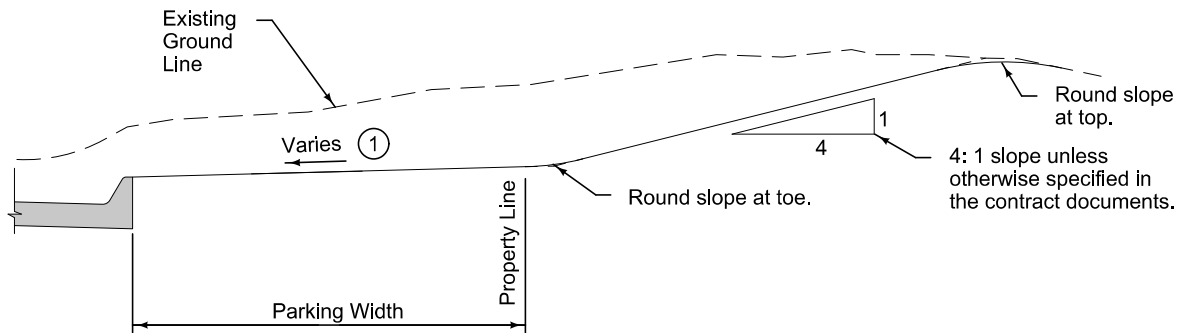

TYPICAL CUT SECTION

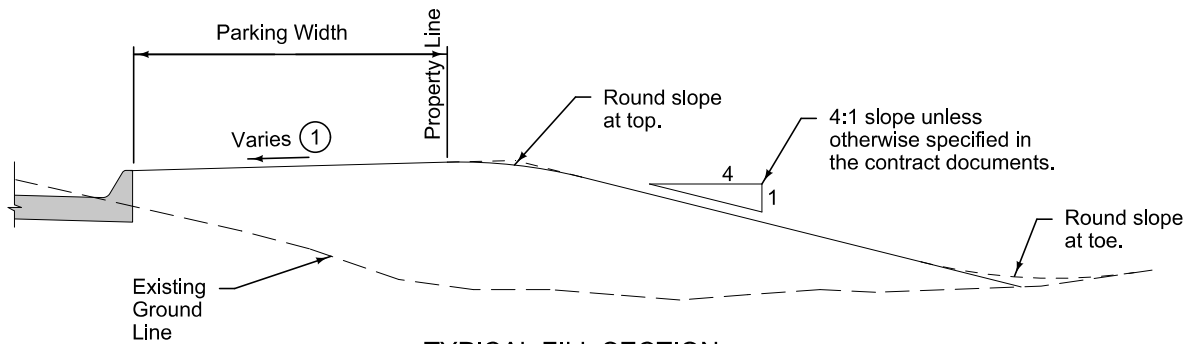

TYPICAL FILL SECTION

- ① Parking Slope:  
 If parking width is less than 10 feet wide, slope at 1/4 inch per foot.  
 If parking width is 10 feet wide and greater, slope at 1/2 inch per foot.

 <b>SUDAS</b>	REVISION
	1   10-21-14
	<b>7030.104</b>
SHEET 1 of 1	
SUDAS Standard Specifications	
RIGHT-OF-WAY GRADING	



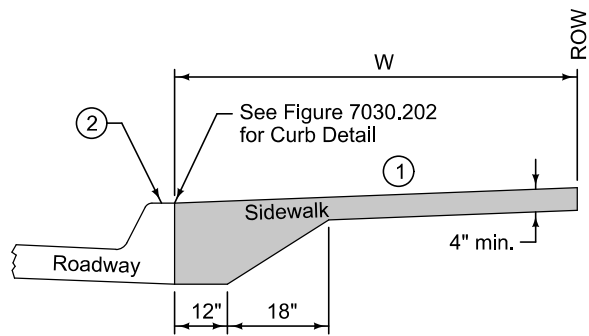

**CLASS A SIDEWALK**  
(Sidewalk extends from back of curb to ROW)

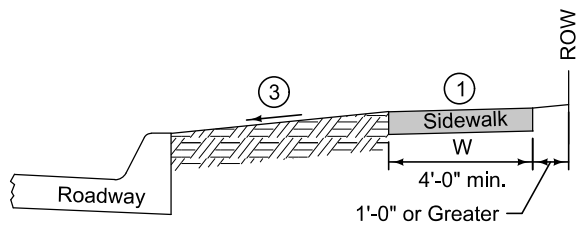

**CLASS B SIDEWALK**

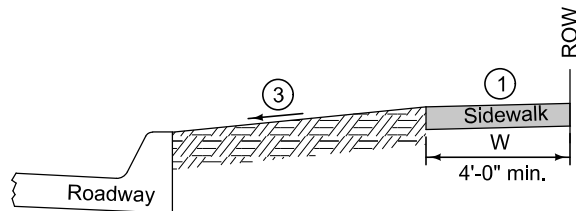

**CLASS C SIDEWALK**

- ① Target cross slope of 1.5% with a maximum cross slope of 2.0% (including sidewalk through driveway).
- ② Ensure top of curb slopes to street for drainage.
- ③ Parking Slopes:  
If parking width is less than 10 feet wide, slope at  $\frac{1}{4}$  inch per foot.  
If parking width is 10 feet wide and greater, slope at  $\frac{1}{2}$  inch per foot.

Special grade may be specified in the contract documents.

W = Sidewalk width as specified in the contract documents.

	REVISION 3   2022 Edition
	<b>7030.201</b>
	SHEET 1 of 1
SUDAS Standard Specifications	
<b>CLASSES OF SIDEWALKS</b>	

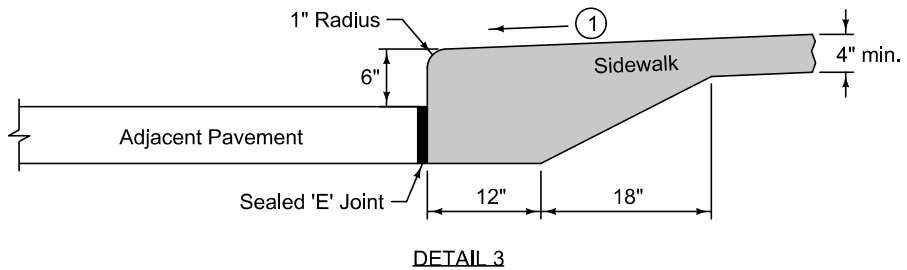
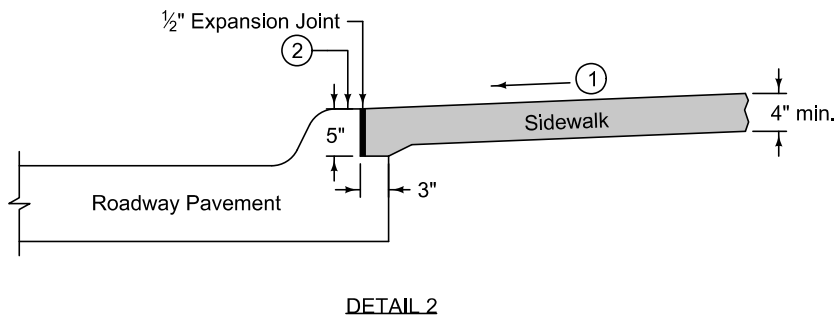
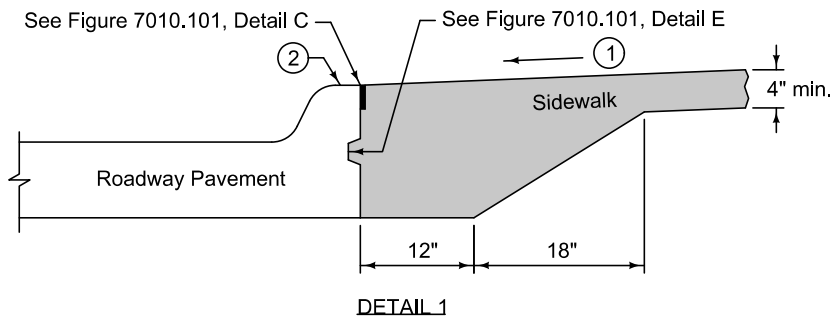

For new sidewalk with new curb and gutter, comply with Detail 1 or Detail 2. Comply with Detail 3 for new sidewalk adjacent to existing pavement or when specified in the contract documents.

- ① Target cross slope of 1.5% with a maximum cross slope of 2.0%.
- ② Ensure top of curb slopes to street for drainage.

 <b>SUDAS</b>	<small>REVISION</small> 3   2022 Edition
	<b>7030.202</b>
	<small>SHEET 1 of 1</small>
SUDAS Standard Specifications	
<b>CURB DETAILS FOR CLASS A SIDEWALK</b>	

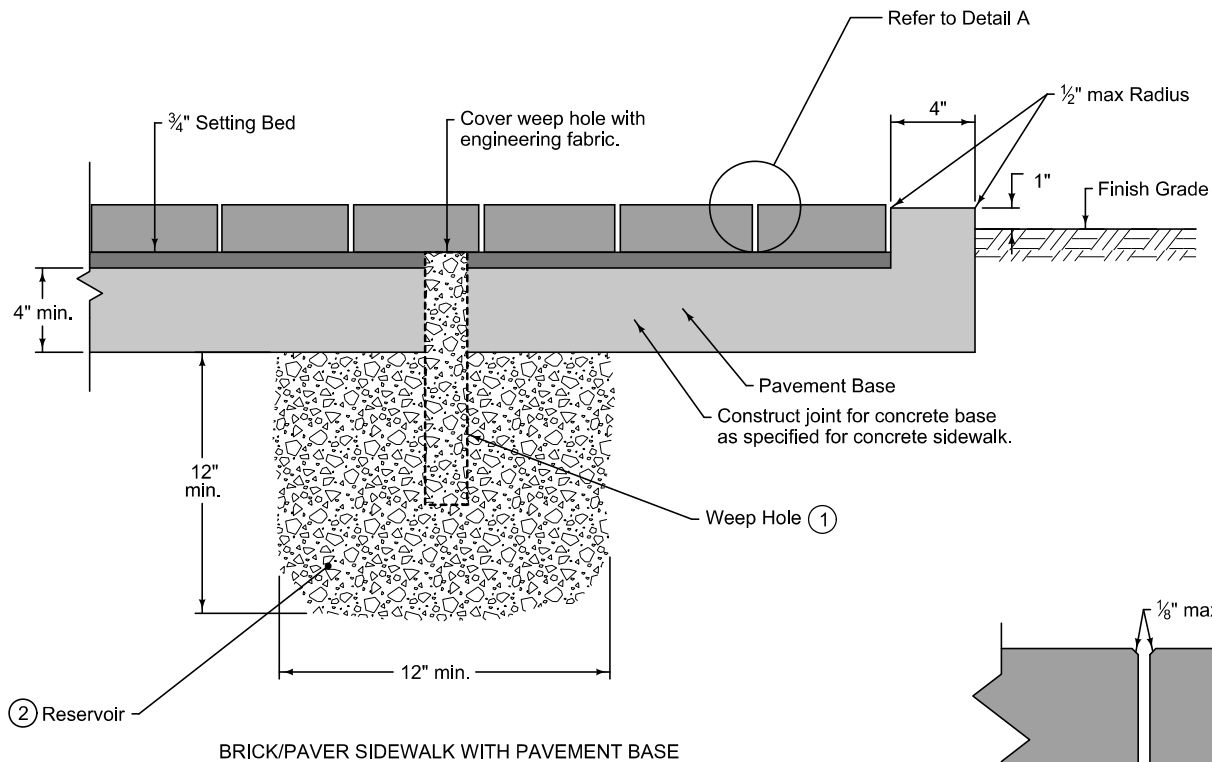

Install brick/paver sidewalk with pattern specified in the contract documents.

- ① Install 2 inch diameter, 12 inch long, PVC pipe even with the top of the asphalt setting bed at locations specified. Fill pipe with 3/4 inch clean rock.
- ② Fill reservoir with 3/4 inch clean rock. Extend reservoir to subdrain if present.

	REVISION	
	2	10-16-18
	<b>7030.203</b>	
SHEET 1 of 1		
SUDAS Standard Specifications		
BRICK/PAVER SIDEWALK		

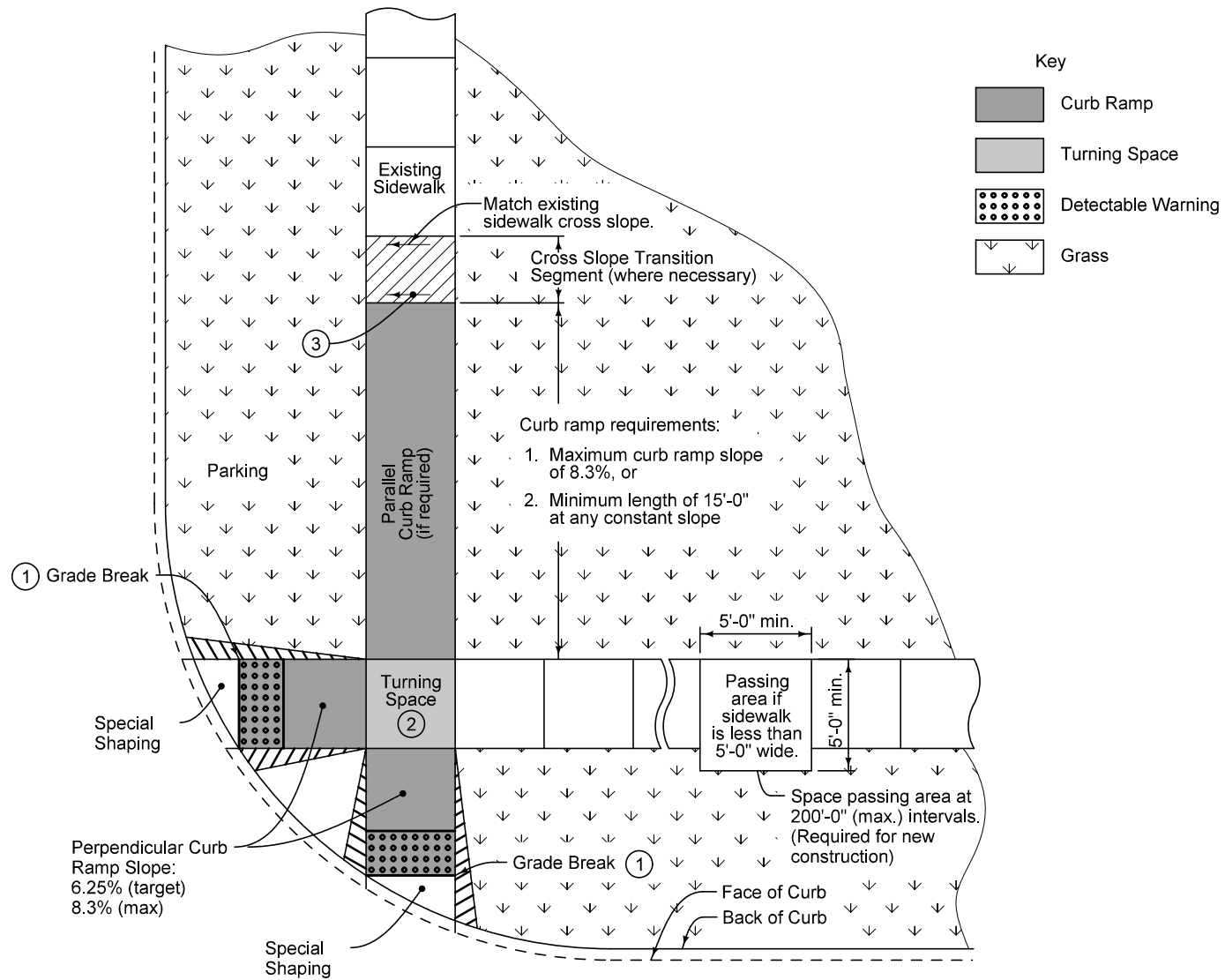

Curb ramp requirements:  
 1. Maximum curb ramp slope of 8.3%, or  
 2. Minimum length of 15'-0" at any constant slope

- ① Match pedestrian street crossing slope, or flatter.
- ② Minimum 4 feet by 4 feet. Target cross slope of 1.5% with a maximum cross slope of 2.0%.
- ③ Target cross slope of 1.5% with a maximum cross slope of 2.0%.

	REVISION 3   10-20-15
	<b>SUDAS 7030.204</b>
	SHEET 1 of 1
SUDAS Standard Specifications	
GENERAL FEATURES OF AN ACCESSIBLE SIDEWALK	

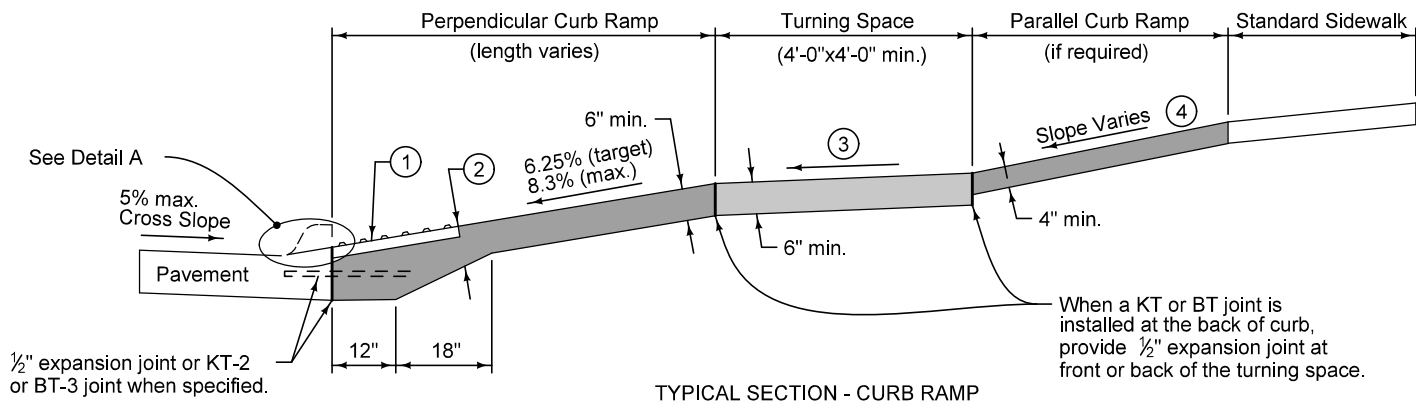

- ① Provide a minimum 2 foot width of detectable warning surfaces in the direction of pedestrian travel across the full width of the curb ramp or turning space, exclusive of curbs or flares.
- ② Provide a minimum of 6 inches of concrete below the detectable warning panel.
- ③ Minimum 4 feet by 4 feet. Target cross slope of 1.5% with a maximum cross slope of 2.0%.
- ④ If normal sidewalk elevation cannot be achieved with the perpendicular ramp between the street and landing due to limited ramp length, provide a parallel ramp to make up the elevation difference between the landing and the standard sidewalk.

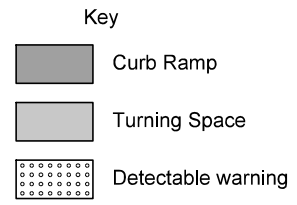

The length of the parallel ramp is not required to exceed 15 feet, regardless of the resulting slope. Do not exceed 8.3% slope for parallel ramps shorter than 15 feet.

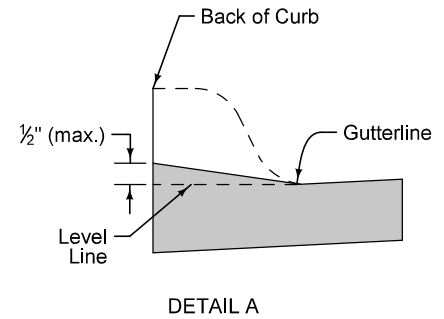

- ⑤ If crossing gate conflicts with location of detectable warning or if pedestrian crossing gate is provided, place detectable warning panel in advance of the crossing gate.
- ⑥ Locate front edge of detectable warning panel 12 to 15 feet from centerline of nearest rail. Orient truncated domes parallel to the direction of pedestrian travel.

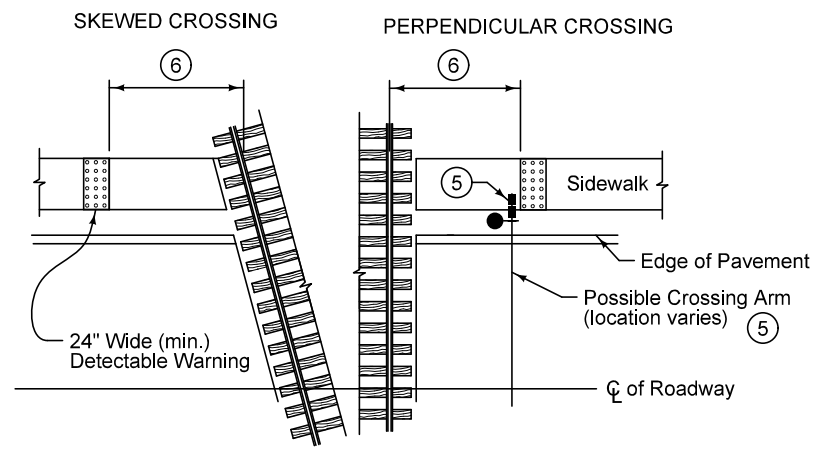

	REVISION
	1   10-20-15
	<b>7030.205</b> SHEET 1 of 1
SUDAS Standard Specifications	
GENERAL SIDEWALK AND CURB RAMP DETAILS	

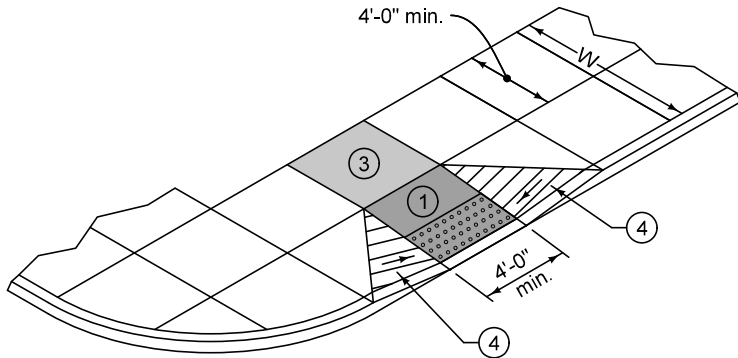

PERPENDICULAR CURB RAMP  
(For Class A Sidewalk)

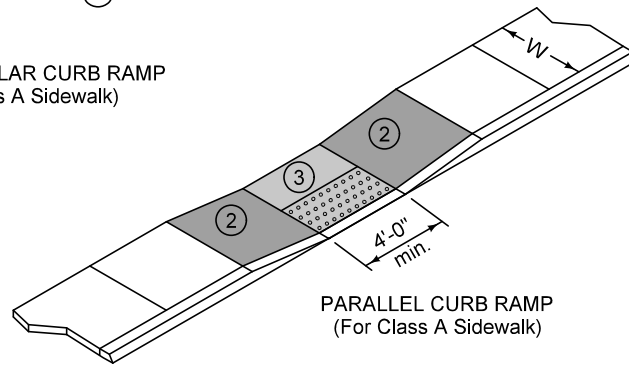

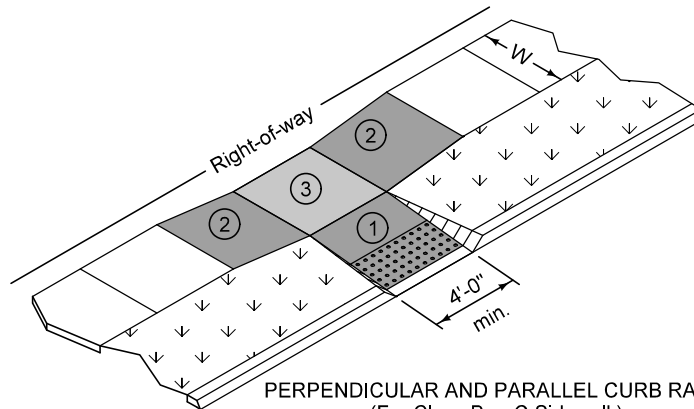

PARALLEL CURB RAMP  
(For Class A Sidewalk)



PERPENDICULAR AND PARALLEL CURB RAMP  
(For Class B or C Sidewalk)

Key

-  Curb Ramp
-  Turning Space
-  Detectable Warning

- ① Perpendicular Curb Ramp: Target running slope of 6.25% with maximum running slope of 8.3%. Match pedestrian street crossing cross slope at back of curb. At mid-block crossings, cross slope may exceed 2.0% to match roadway grade.
- ② Parallel Curb Ramp: Target cross slope of 1.5% with a maximum cross slope of 2.0%. The length of the parallel ramp is not required to exceed 15 feet, regardless of resulting slope. Do not exceed 8.3% slope for parallel ramps shorter than 15 feet.
- ③ Turning Space: Target slope of 1.5%, with a maximum slope perpendicular to the travel directions of 2.0%. At mid-block crossings, cross slope of landing may exceed 2.0% to match roadway grade. Minimum 4 feet by 4 feet.
- ④ Flare (10:1 max.) required if ramp is contiguous with sidewalk.

	REVISION
	New   10-16-12
	<b>7030.206</b>
SHEET 1 of 1	

SUDAS Standard Specifications

CURB RAMPS OUTSIDE OF  
INTERSECTION RADIUS

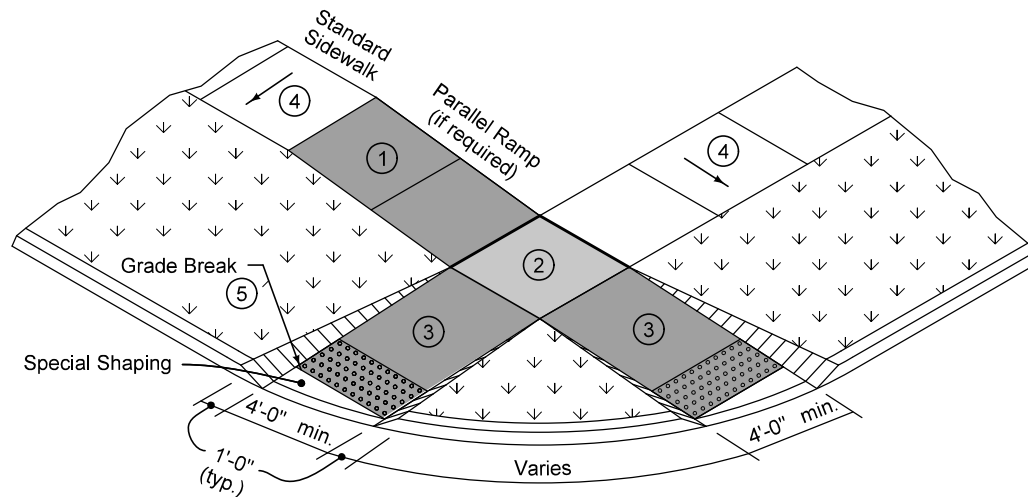





- ① Parallel Curb Ramp: If normal sidewalk elevation cannot be achieved with the perpendicular ramp between the street and landing due to limited ramp length, provide a parallel ramp to make up the elevation difference between the landing and the standard sidewalk.

The length of the parallel ramp is not required to exceed 15 feet, regardless of the resulting slope. Do not exceed 8.3% slope for parallel ramps shorter than 15 feet.

- ② Turning Space: Target slope of 1.5% with maximum slope perpendicular to the travel directions of 2.0%. Minimum 4 feet by 4 feet.
- ③ Perpendicular Curb Ramp: Target running slope of 6.25% with maximum running slope of 8.3%.
- ④ Target cross slope of 1.5% with a maximum cross slope of 2.0%.
- ⑤ Match pedestrian street crossing cross slope or flatter.

Key

-  Curb Ramp
-  Turning Space
-  Detectable warning
-  Grass



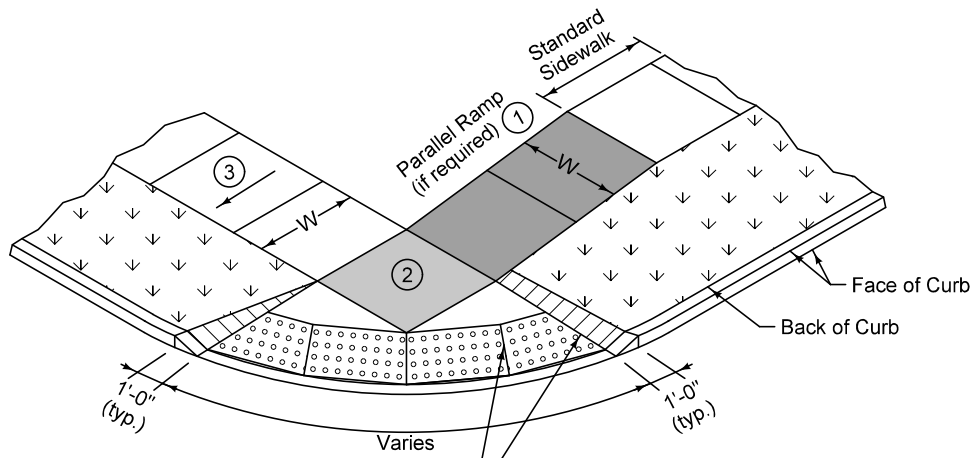

	<small>REVISION</small> New 10-16-12
	<b>SUDAS</b> <b>7030.207</b>
	<small>SHEET 1 of 1</small>
<b>SUDAS Standard Specifications</b>	
<b>CURB RAMP FOR CLASS B OR C SIDEWALK</b>	



Cut panels as required to provide continuous detectable warning surface around radius.

- ① Parallel Curb Ramp: If normal sidewalk elevation cannot be achieved with the perpendicular ramp between the street and landing due to limited ramp length, provide a parallel ramp to make up the elevation difference between the landing and the standard sidewalk.  
  
The length of the parallel ramp is not required to exceed 15 feet, regardless of the resulting slope. Do not exceed 8.3% slope for parallel ramps shorter than 15 feet.
- ② Turning Space: Target slope of 1.5% with maximum slope perpendicular to the direction of travel of 2.0%. Minimum 4 feet by 4 feet.
- ③ Target cross slope of 1.5% with a maximum cross slope of 2.0%.

Key

-  Curb Ramp
-  Turning Space
-  Detectable warning
-  Grass

	<small>REVISION</small> 1   2022 Edition
	<b>7030.208</b> <small>SHEET 1 of 1</small>
SUDAS Standard Specifications	
<b>ALTERNATIVE CURB RAMP FOR CLASS B OR C SIDEWALK</b>	



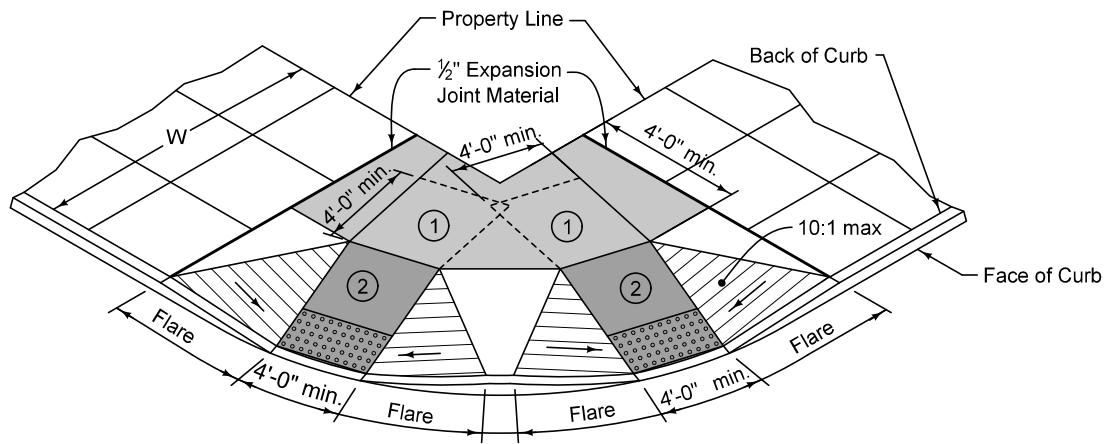



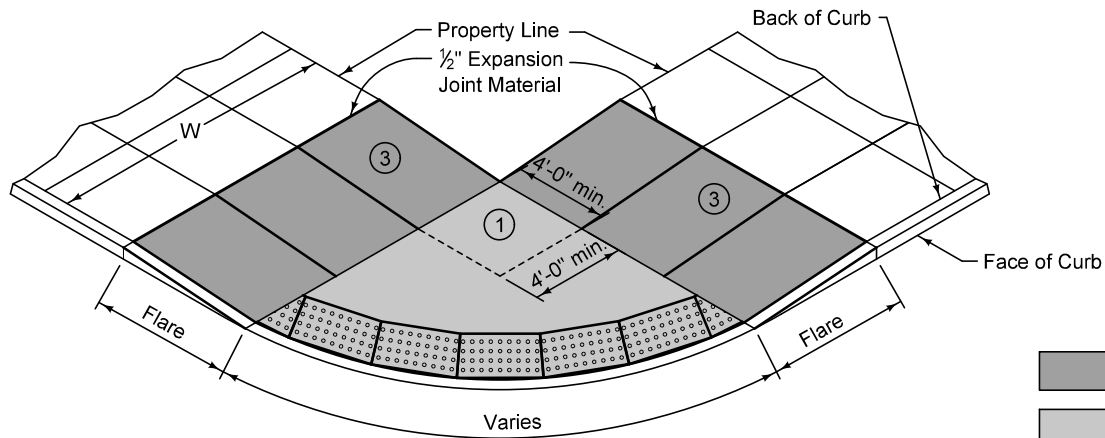

CLASS A SIDEWALK CURB RAMP



CLASS A SIDEWALK CURB RAMP ALTERNATIVE

- Key
-  Curb Ramp
  -  Turning Space
  -  Detectable Warning

- ① Turning Space: Target slope of 1.5% with maximum slope perpendicular to the travel direction of 2.0%. Minimum 4 feet by 4 feet (turning spaces may overlap).
- ② Perpendicular Curb Ramp: Target running slope of 6.25% with maximum running slope of 8.3%.
- ③ Parallel Curb Ramp: Target running slope of 6.25% with maximum running slope of 8.3%. The length of the parallel ramp is not required to exceed 15 feet, regardless of the resulting slope. Do not exceed 8.3% for parallel ramps shorter than 15 feet.

	REVISION New 10-16-12
	<b>7030.209</b>
	SHEET 1 of 1
SUDAS Standard Specifications	
CURB RAMPS FOR CLASS A SIDEWALK	

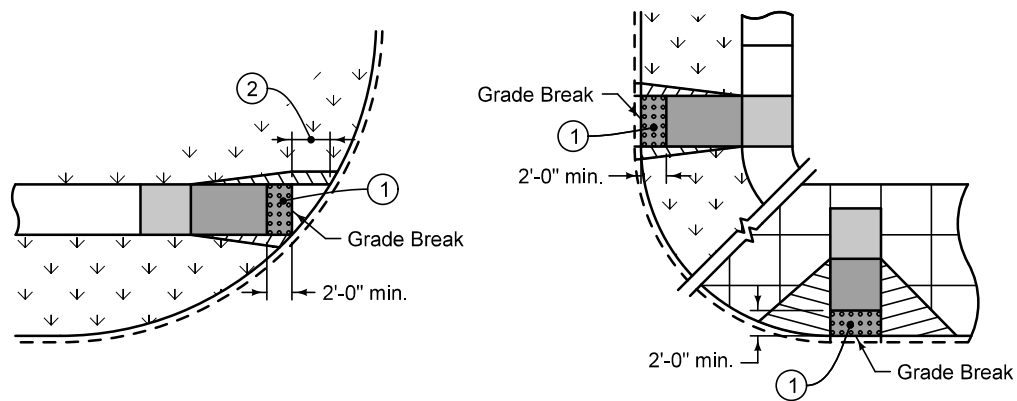

PERPENDICULAR RAMPS

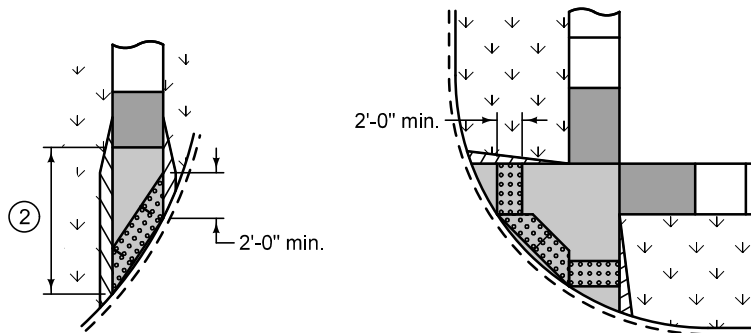
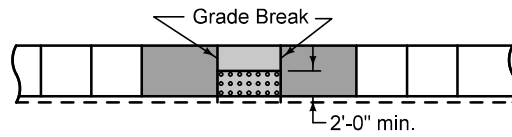



PARALLEL RAMPS

Provide a minimum 2 foot width of detectable warning surfaces in the direction of pedestrian travel across the full width of the curb ramp or turning space, exclusive of curbs or flares.

- ① When detectable warning is located on curb ramp surface, orient domes in the direction of pedestrian travel.
- ② When the distance between the grade break and the back of curb is less than 5 feet, place detectable warning surface at the bottom of the curb ramp.

Where one corner of the curb ramp is more than 5 feet from the back of curb, construct curb ramp as a parallel curb ramp. Move grade break back as required to place detectable warning on turning space at the back of curb.

Key

-  Curb Ramp
-  Turning Space
-  Detectable Warning

	REVISION
	New 10-16-12
	<b>7030.210</b>
SHEET 1 of 1	

SUDAS Standard Specifications

DETECTABLE WARNING PLACEMENT